



The James E-Meter

For the determination of the resonant frequency of materials.

Features and Benefits

- Conforms to ASTM C-215 and C-666.
- The only method of calculating the following material parameters non destructively:

**Youngs Modulus of Elasticity,
Modulus of Rigidity,
Poissons Ratio,
Damping Constant.**

- Available for specimen sizes up to 6 inches (150mm) cross section dimension and from 1.75 inches (45mm) to 28 inches (700mm) in length.
- Semi automatic feature facilitates the fast identification of resonance.

The James E-Meter

Principle

The E-Meter measures the resonant frequencies of the three different modes of vibration –

Longitudinal,
Transverse (Flexural),
Torsional.

From these the following material characteristics can be calculated –

Youngs Modulus of Elasticity,
Modulus of Rigidity,
Poissons Ratio,
Damping Constant.

The principle used in the E-Meter is based upon the determination of the fundamental resonant frequency of vibration of a specimen by a driver oscillator, sensed by an accelerometer and then amplified on a meter.

The E-Meter has a semi automatic feature which eliminates cumbersome manual scanning. Frequencies are automatically scanned in one of the four ranges and the maximum amplitude is registered. The instrument automatically stops scanning at the beginning of the band containing the resonant frequency.

Durability of Concrete and Refractories

The determination of flexural resonance is very important when studying the degradation of concrete under accelerated freezing and thawing cycles and aggressive environments on concrete specimens as well as thermal cycling of refractory materials. The advantage of resonance methods are: –

1. Tests can be repeated over a very long period on the same specimen; the number of test specimens required is therefore greatly reduced.
2. The results obtained with the flexural resonance method on the same specimen are more reproducible than those obtained with destructive tests and groups of specimens.

The E-Meter, in addition to conforming to ASTM C-215 for determining resonant frequency can be adapted for –

ASTM C-623	Glass
ASTM C-747	Carbon and Graphite
ASTM C-848	Ceramic Whiteware
ASTM C-885-78	Refractories
ASTM C-666	Concrete – Freeze Thaw.

E-Meter with Standard Bench

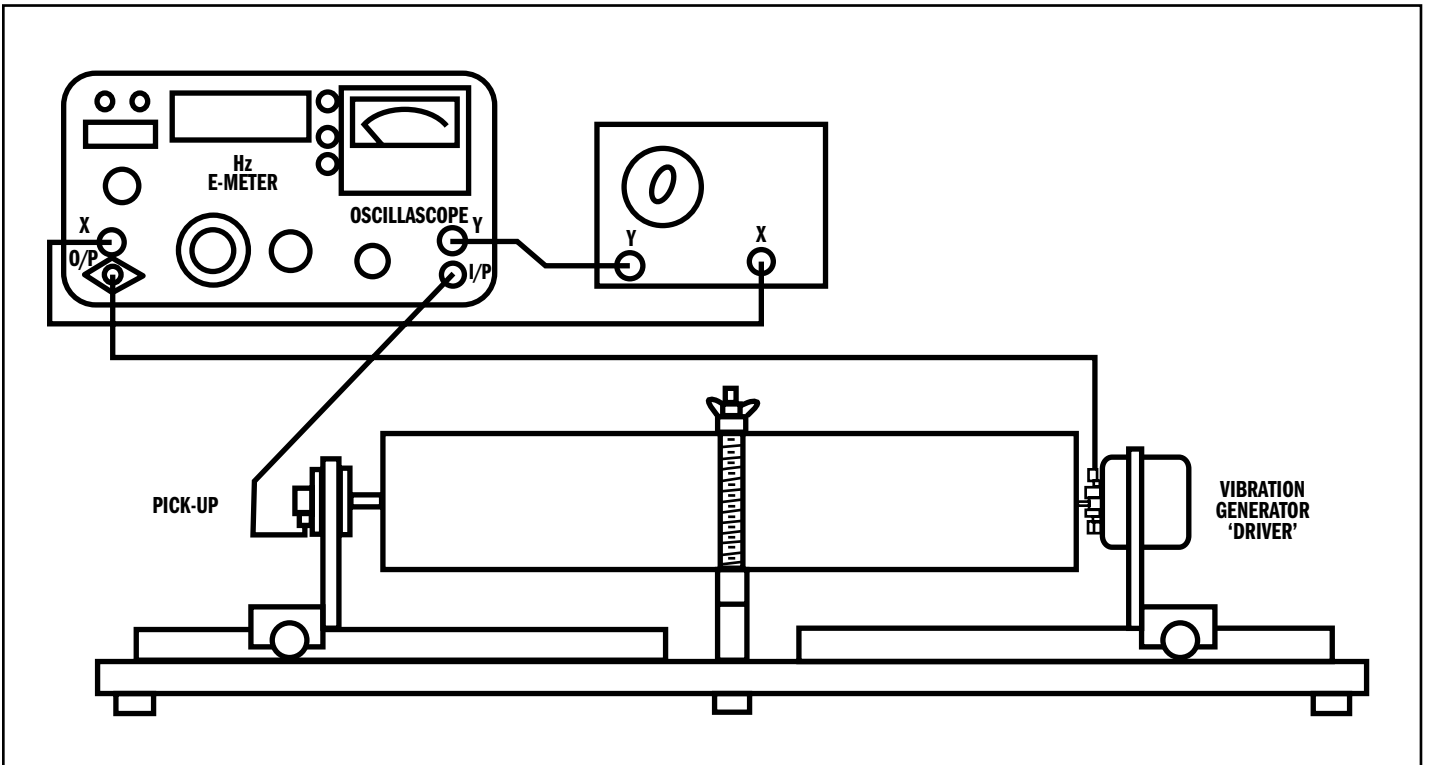
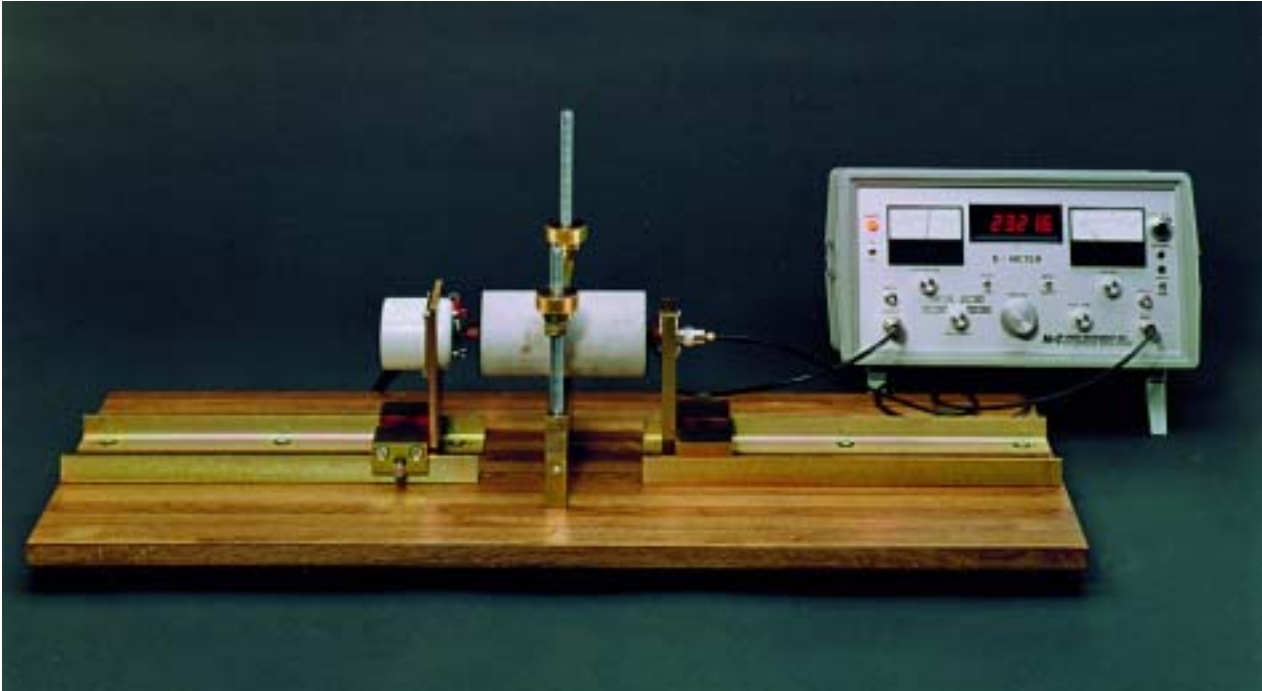

E-Meter shown with electro-dynamic test bench with contact type vibration generator and piezo-electric accelerometer contact pick-up. Arranged for longitudinal resonance test of a 500x100x100mm concrete prism.

Specifications

Frequency range	10 Hz to 100 kHz in 4 switched ranges
Fine Control	Two speed control 10:1 and 50:1
Stability including frequency indicator	Typically 0.04%, 10 minutes after switch on
Output	0 to 14 V pk-pk into 3 ohms (5 V RMS into 3 ohms, 8.3 watts)
Output Indicator	0 – 10 V miniature meter
Output Monitor	1 V pk. from BNC socket for CRO 'X' Drive

Frequency Indicator

Display	6 digit LED
Gate times	1 sec. or 10 sec. switch selected, LED indicated. Accuracy 20 ppm \pm 1 count over full operating temperature range

Resonance Indicator

Indicator	70 mm scale length meter graduated 0 – 100 with indicator at 70.7 point for bandwidth measurement
Input amplifier sensitivity	1 mV for full scale deflection
Bandwidth 3 db points	20 Hz to 350 kHz
Input Impedance	10 Mohm
Lower 3 db point with 500 pF accelerometer-type pick-up	35 Hz
Output Monitor	2.5 V pk. for full scale deflection from BNC socket for CRO 'Y' drive

Standard System Driving Transducer

Large mass specimens Contact vibration generator

Vibration Pick-Up Transducer

Large mass specimens Miniature crystal accelerometer

Operating Temperature Range

0°C to 40°C

Power Supply

120/240 V 50 – 60 Hz

Sales Numbers

V-C-4959	E-Meter Standard Test System
V-C-4959-11	E-Meter Instrument only
V-085-10318	Vibrator
V-062-10319	Accelerometer
V-081-10315-000	Standard Bench, Vibrator and Accelerometer

NDT JAMES INSTRUMENTS INC.
NON DESTRUCTIVE TESTING SYSTEMS

3727 North Kedzie Avenue,
Chicago, Illinois 60618
1-800-426-6500 (773) 463-6565
FAX (773) 463-0009
e-mail: info@ndtjames.com
<http://www.ndtjames.com>